



VinylCrest[®] 200 Gliding Window Parts Reference Catalog

#597779

VINYLCREST[™] 200

FOR PRODUCT PRODUCED AFTER 05/95



Gliding Window includes:

- Single Gliding
- End Vent
- Equal End Vent

GLIDING
WINDOW

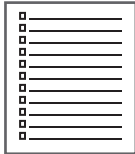

Order Form

ORDER
FORM

©2006, SNE Enterprises, Inc.



Order Form

Please Read First

Complete All Applicable Sections and Items

An Order Form must be completed for each type* of unit.
(*e.g., Half Round, Quarter Round)

I AM ORDERING: (Check all that apply)

- | | | |
|--|--|--|
| <input type="checkbox"/> Replacement Sash | <input type="checkbox"/> Replacement Screen | <input type="checkbox"/> Replacement Exterior Trim |
| <input type="checkbox"/> Replacement Glass | <input type="checkbox"/> Replacement Interior Trim | <input type="checkbox"/> Other _____ |
| <input type="checkbox"/> Replacement Glazing Beads | | (Please Specify) |

ORDER FORM

Section 1 REQUIRED

UNIT INFORMATION

1. Manufacturing Date/Glass Identification Number(s) _____

(Please include Original Order/Item Number if possible)

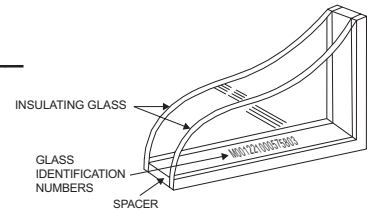

2. Unit Ordering Code _____

(See pages 10-12 in the Gliding Window Section Part # 597777)

3. Color White Almond

4. Quantity _____ (Total # of units requiring replacement parts)

5. Product Style Single Gliding End Vent Equal End Vent

6. Position Operating Sash (Inside / Interior of Home) Fixed Sash (Outside / Exterior of Home)

7. Operating Sash Location (As viewed from the exterior) Left Right

Section 2

GLASS OPTIONS

8. Glazing

- SmartR® (Low-E²) Easy Care™ (Low-E²) Clear Insulated Sun 140 (Southern Low-E²)

9. Tempered Glass

- Yes No

10. Airspace Options

- None Argon-Filled High Altitude

11. Glass Tint

- None Bronze Gray

12. Glass Options

- None Obscure Sound Controlled (Laminated .030)

Drawings not to scale.



Example

Section 1 REQUIRED

UNIT INFORMATION

1. Manufacturing Date/Glass Identification Numbers A30095X27C3M
22113002585 or 001-01
(Please include Original Order/Item Number if possible)

Required

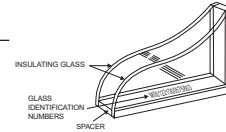

2. Unit Ordering Code 2'6" x 4'0"
(See pages 10-12 in the Gliding Window Section Part # 59777)

3. Color White Almond

**Please look for Rough Opening
(Width x Height)**

4. Quantity 2 *(Total # of units requiring replacement parts)*

5. Product Style Single Gliding End Vent Equal End Vent

6. Position Operating Sash *(Inside / Interior of Home)* Fixed Sash *(Outside / Exterior of Home)*

7. Operating Sash Location *(As viewed from the exterior)* Left Right



**Gliding Window
Order Form**

Order Form
Please Read First

I AM ORDERING: (Check all that apply)

<input type="checkbox"/> Replacement Sash	<input type="checkbox"/> Replacement Screen	<input type="checkbox"/> Replacement Exterior Trim
<input type="checkbox"/> Replacement Glass	<input type="checkbox"/> Replacement Interior Trim	<input type="checkbox"/> Other _____ <i>(Please Specify)</i>
<input type="checkbox"/> Replacement Glazing Beads		

**Section 1
REQUIRED** UNIT INFORMATION

1. Manufacturing Date/Glass Identification Numbers _____
(Please include Original Order/Item Number if possible)

2. Unit Ordering Code _____
(See pages 10-12 in the Gliding Window Section Part # 59777)

3. Color White Almond

4. Quantity _____ *(Total # of units requiring replacement parts)*

5. Product Style Single Gliding End Vent Equal End Vent

6. Position Operating Sash *(Inside / Interior of Home)* Fixed Sash *(Outside / Exterior of Home)*

7. Operating Sash Location *(As viewed from the exterior)* Left Right

**Section 2
REQUIRED** GLASS OPTIONS

8. Glazing
 SmarTR[®] (Low-E) Easy Care[™] (Low-E²) Clear Insulated Sun 140 (Southern Low-E²)

9. Tempered Glass
 Yes No

10. Airspace Options
 None Argon-Filled High Altitude

11. Glass Tint
 None Bronze Gray

12. Glass Options
 None Obscure Sound Controlled (Laminated .030)

Drawings not to scale.

970 CATALOG: CVP PRODUCT: SG I (2/06) www.crestlinewindows.com



ORDER
FORM

13. Grille Style

No Grille(s)

Colonial

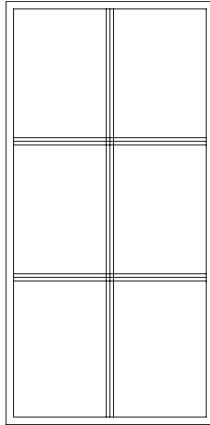

Prairie

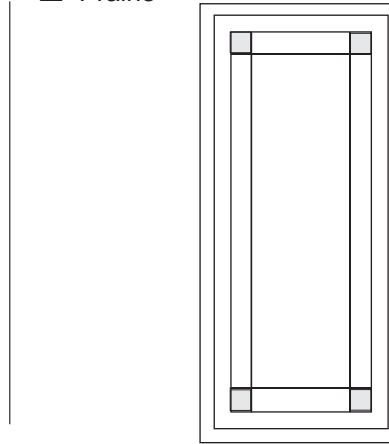

For Prairie style, please circle set-back size.

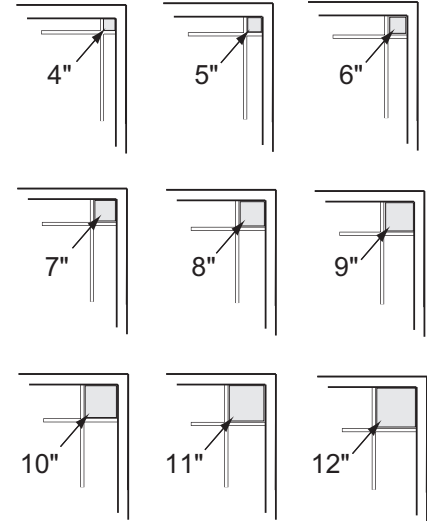

Note: 4" Set-back is standard

14. Grille Type

5/8" Flat Grilles In Airspace (GIA) 

3/4" Profiled Grilles In Airspace (GIA) 

Optically Divided Lite (V-Groove)

15. Grille Color

White Almond

16. Grille Pattern

Standard

Custom (Please attach a drawing when ordering a Custom Pattern.)

Section 3

EXTERIOR/INTERIOR ACCESSORIES

17. Exterior Accessories

Simulated Flat Casing Flat Casing Return

Simulated Brickmould 5/8" J-Channel 7/8" J-Channel Masonary Flange

Replacement Nailing Fin Trim Connector

18. Interior Accessories

1/2" Drywall Receptor 5/8" Drywall Receptor 3/4" Trim Receptor Extension Jamb Clip

Jamb Extenders: Size _____

Material: Pine Composite