



# VinylCrest® 200 Picture & Transom Parts Reference Catalog

#597780

VINYLCREST™ 200

FOR PRODUCT PRODUCED AFTER 05/94

Transom Direct Set



Picture Direct Set



Use with:

- 930 Single Hung
- 930 Double Hung
- 930 Gliding Window

PICTURE &  
TRANSOM

Mull/Stack

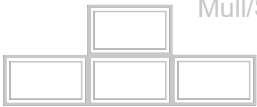

Use with:

- 930 Single Hung
- 930 Double Hung

**NOTE:**

Gliding Windows CANNOT be mulled or stacked with the 930 Picture & Transom units OR with another Gliding Window.

MULL/  
STACK

Order Form

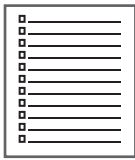

ORDER  
FORM



### Order Form

**Please Read First**

**Complete All Applicable Sections and Items**

An Order Form must be completed for each type\* of unit.  
(\*e.g., Half Round, Quarter Round)

I AM ORDERING: (Check all that apply)

- Replacement Glass
- Replacement Exterior Trim
- Other \_\_\_\_\_  
*(Please Specify)*
- Replacement Glazing Beads
- Replacement Interior Trim

### Section 1 REQUIRED

# UNIT INFORMATION

ORDER  
FORM

1. Manufacturing Date/Glass Identification Number(s) \_\_\_\_\_

\_\_\_\_\_  
*(Please include Original Order/Item Number if possible)*

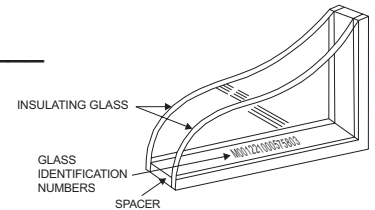

2. Unit Ordering Code \_\_\_\_\_

*(See pages 5-11 in the Picture & Transom Section Part # 597778)*

3. Color  White  Almond

4. Quantity *(Total # of units requiring Replacement Parts)* \_\_\_\_\_

Quantity Left-Hand\* \_\_\_\_\_ Quantity Right-Hand\* \_\_\_\_\_ *(\*Left and Right quantities are required for Quarter Radius Units only)*

Quantity Not Handed \_\_\_\_\_

### 5. Shape Handing

Width \_\_\_\_\_ Height \_\_\_\_\_ Short Leg Height\*\* \_\_\_\_\_ *(\*\*Short Leg Height is required for Extended Leg Radius Units only)*

### 6. Special Shapes

1/2 Round  1/4 Round  Ellipse  Eyebrow  Modified Eyebrow

Other *(Special Shape\*)* \_\_\_\_\_ *(\*Please include shape)*



### Example

#### Section 1 REQUIRED UNIT INFORMATION

1. Manufacturing Date/Glass Identification Numbers **Required** A30095X27C3M

2213002585 / 001-01  
(Please include Original Order/Item Number if possible)

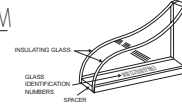

2. Unit Ordering Code N/A if Special Shapes are listed  
(See pages 5-11 in the Picture/Transom Section Part# 597778)

3. Color  White  Almond

**Please look for Rough Opening (Width x Height)**

4. Total Quantity of units requiring Replacement Parts 1

Quantity Left-Hand\* 1 Quantity Right-Hand\* 0 (\*Left and Right quantities are required for Quarter Radius Units only)

Quantity Not Handed 0

5. Shape Handing

Width 12" Height 14" Short Leg Height\*\* \_\_\_\_\_ (\*\*Short Leg Height is required for Extended Leg Radius Units only)

5. Special Shapes

1/2 Round  1/4 Round  Ellipse  Eyebrow  Modified Eyebrow

Other (Special Shape\*) Right Triangle (\*Please include shape)

**Required in units available with LEFT or Right orientation.**

**Please look for Rough Opening (Width x Height)**

**Picture & Transom Window Order Form**

---

**Order Form**  
*Please Read First*

I AM ORDERING: (Check all that apply)

Replacement Glass  Replacement Exterior Trim  Other \_\_\_\_\_ (Please Specify)

Replacement Glazing Beads

Replacement Interior Trim

**Complete All Applicable Sections and Items**

An Order Form must be completed for each type\* of unit. (\*e.g., Half Round, Quarter Round)

---

**Section 1 REQUIRED**

**UNIT INFORMATION**

1. Manufacturing Date/Glass Identification Numbers \_\_\_\_\_  
(Please include Original Order/Item Number if possible)

2. Unit Ordering Code \_\_\_\_\_  
(See pages 5-11 in the Picture/Transom Section Part# 597778)

3. Color  White  Almond

4. Total Quantity of units requiring Replacement Parts \_\_\_\_\_

Quantity Left-Hand\* \_\_\_\_\_ Quantity Right-Hand\* \_\_\_\_\_ (\*Left and Right quantities are required for Quarter Radius Units only)

Quantity Not Handed \_\_\_\_\_

5. Shape Handing

Width \_\_\_\_\_ Height \_\_\_\_\_ Short Leg Height\*\* \_\_\_\_\_ (\*\*Short Leg Height is required for Extended Leg Radius Units only)

5. Special Shapes

1/2 Round  1/4 Round  Ellipse  Eyebrow  Modified Eyebrow

Other (Special Shape\*) \_\_\_\_\_ (\*Please include shape)

Drawings not to scale  
 930 CATALOG: CVP | (1/06) www.crestlinewindows.com



### Section 2

# GLASS OPTIONS

#### 7. Glazing

- SmartR® (Low-E<sup>2</sup>)
- Easy Care™ (Low-E<sup>2</sup>)
- Clear Insulated
- Sun 140 (Southern Low-E<sup>2</sup>)

#### 8. Tempered Glass

- Yes
- No

#### 9. Airspace Options

- None
- Argon-Filled
- High Altitude

#### 10. Glass Tint

- None
- Bronze
- Gray

#### 11. Glass Options

- None
- Obscure
- Sound Controlled (Laminated .030)

#### 12. Grille Style

- No Grille(s)

- Colonial

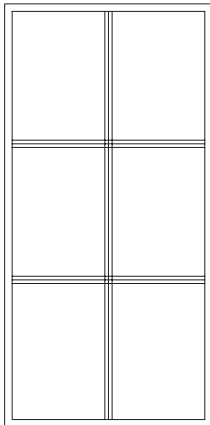

- Prairie

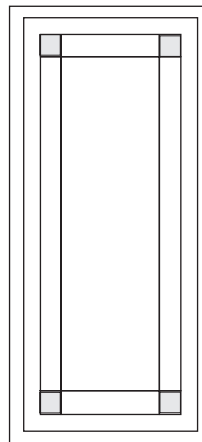

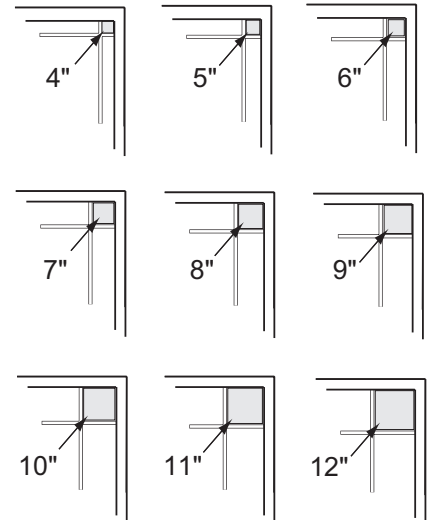

For Prairie style, please circle set-back size.



Note: 4" Set-back is standard

#### 13. Grille Type

- 5/8" Flat Grilles In Airspace (GIA) 
- 3/4" Profiled Grilles In Airspace (GIA) 
- Optically Divided Lite (V-Groove)

#### 14. Grille Color

- White
- Almond

#### 15. Grille Pattern

- Standard
- Custom (Please attach a drawing when ordering a Custom Pattern)



**Section 3**

# EXTERIOR/INTERIOR ACCESSORIES

**16. Exterior Accessories**

- Simulated Flat Casing    Flat Casing Return  
 Simulated Brickmould    5/8" J-Channel    7/8" J-Channel    Masonry Flange  
 Replacement Nailing Fin    Trim Connector

**17. Interior Accessories**

- 1/2" Drywall Receptor    5/8" Drywall Receptor    3/4" Trim Receptor    Extension Jamb Clip  
 Jamb Extenders:   Size \_\_\_\_\_  
Material:    Pine    Composite

ORDER  
FORM